

**POWERSWITCH**  
Semiconductor Contactor With Analogue Input  
For Pulsed Output BF 9250/0\_2

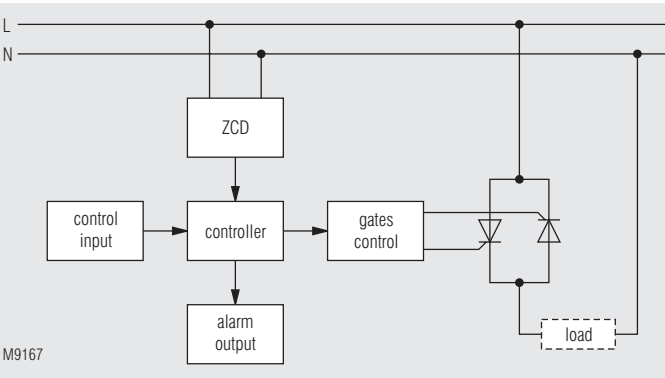

- Analogue controller for accurate process temperature control
- Burst firing control of heaters
- Control input optional with DC 0 ... 10 V, DC 4 ... 20 mA, 0 ... 10 kΩ
- Reverse action operation possible
- Rated operational voltage range up to 480 V
- Rated operational current is up to AC 50 A
- Zero cross switching
- Protected by varistors
- Temperature protection of the power semiconductors
- LED indications for supply, output status and alarm status
- Alarm indication on mains synchronisation failure
- Alarm indication on control input failure
- Alarm indication on over temperature of power semiconductors
- DIN-rail mountable
- BF 9250/0\_2 to 10 A: Width 22.5 mm
- BF 9250/0\_2 to 25 A: Width 45 mm
- BF 9250/0\_2 to 50 A: Width 90 mm

**Block Diagram**



M9167

**Approvals and Markings**



**Applications**

- Analogue control for precise temperatur control
- Fast and noiseless switching of heating elements

**Indicators**

**Normal operation**

- Green LED: ON
- Yellow LED: ON according to output status
- Red LED: OFF

**Mains synchronisation failure alarm**

- Green LED: Flashing
  - Yellow LED: OFF
  - Red LED: Flashing
- (This alarm status is not latched)

**Control input failure**

- Green LED: ON
  - Yellow LED: OFF
  - Red LED: Flashing
- (This alarm status is not latched)

**Over temperature of power semiconductors alarm**

- Green LED: ON
  - Yellow LED: OFF
  - Red LED: ON
- (This alarm status is latched. Supply on A1+/A2 has to be switched off and back on after a short time to reset this status)

**Circuit Diagrams**

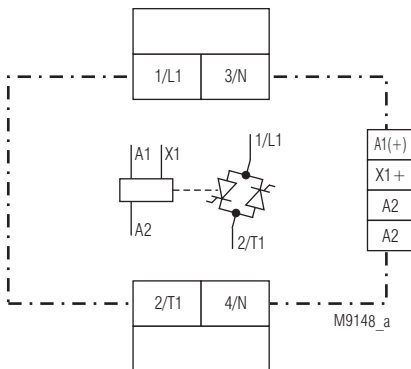

M9148\_a

**Connection Terminals**

Terminal Designation	Signal Designation
A1 (+)	+ / L
A2	- / N
X1	Control input
L1, N	Mains connection
T1, N	Load output

## Technical Data

### Input

#### Supply voltage $U_H$

A1/A2: AC/DC 24 V  
Supply current: < 26 mA at DC 24 V

### Control Input

#### Current controlled input

Control current range: DC 0 ... 20 mA or DC 4 ... 20 mA  
Allowable input current: < 35 mA  
Over current protection: YES  
Alarm for over current: YES  
Reverse polarity protection: YES  
Voltage drop: 1.02 V at 20 mA

#### Voltage controlled input

Control voltage range: DC 0 ... 5 V or DC 0 ... 10 V  
Control input current: < 0.01 mA at DC 10 V

#### Potentiometer controlled input

Potentiometer value: 10 k $\Omega$   $\pm$ 10 %

#### Control accuracy

Range: 0 ... 100 %  
Step: 1.5625 %

### Output

Nominal load voltage: AC 24 ... 115 V; AC 110 ... 240 V or  
AC 230 ... 480 V

Load current  $I_L$ : AC 10 A, 25 A, 50 A

Minimum operational current: AC 40 mA

Operating mode: Continuous

#### Current reduction over 40°C

$I_L$  AC 10 A: 0.2 A / °C

$I_L$  AC 25 A: 0.4 A / °C

$I_L$  AC 50 A: 0.6 A / °C

Frequency range: 45 ... 65 Hz

Varistor voltage: AC 510 V

Load types: Resistive

Power loss: 1.2 (V)  $\times$   $I_L$  (A) approx.

Average power output: 0 ... 100 %

#### Output power resolution

at BF 9250/002: 1.5625 %

at BF 9250/042: 5 %

Zero crossing detection: YES

#### Off state leakage current at

rated voltage and frequency: 1.0 mA  
( $T_j$  = 125°C max.)

#### $I^2t$ for fusing $t = 1$ to 10 ms

$I_L$  AC 10 A, 25 A: 800 A<sup>2</sup>s

$I_L$  AC 50 A: 1800 A<sup>2</sup>s

Peak inverse voltage:  $\pm$ 1200 V<sub>p</sub>

Note: Higher current capacities on request

### Installation

#### Recommended distance with max. load current and 100 % duty cycle upper / lower side

to cable duct: 20 mm  
left / right: 10 mm

## Technical Data

### General Data

Maximum humidity: 75 %, no condensation  
Operating temperature: 0 ... 40°C  
Maximum temperature: 60° (using appropriate derating)  
Storage temperature: - 20 ... + 80°C  
Cooling: Natural convection  
Junction temperature: < 125°C

#### Rated withstand voltage

input to output: 3500 V

#### Degree of protection

Housing: IP 40 IEC/EN 60 529  
Terminals: IP 20 IEC/EN 60 529  
Mounting: DIN rail IEC/EN 60 715

#### Wire fixing

#### Wire connection

Load terminals: 1 x 10 mm<sup>2</sup> solid  
1 x 6 mm<sup>2</sup> stranded wire with sleeve  
1 x 0.75 mm<sup>2</sup> stranded wire with sleeve  
and with insulation  
1 x 1.5 mm<sup>2</sup> stranded wire with sleeve  
and with insulation

#### Load terminals:

box terminals

#### Control terminals:

cage clamps

Fixing torque: 1.2 Nm

#### Weight

BF 9250/0\_2 to 10 A: 350 g

BF 9250/0\_2 to 25 A: 580 g

BF 9250/0\_2 to 50 A: 1094 g

### Dimensions

#### Width x height x depth

BF 9250/0\_2 to 10 A: Width 22,5 x 85 x 120 mm

BF 9250/0\_2 to 25 A: Width 45 x 85 x 120 mm

BF 9250/0\_2 to 50 A: Width 90 x 85 x 120 mm

## UL-Data according to UL508

### Input

Wire connection: 60°C / 75°C copper conductors only  
AWG 24 - 14 Sol/Str

### Control input

Current input: DC 4 ... 20 mA  
Voltage input: DC 0 ... 5 V bzw. DC 0 ... 10 V  
Potentiometer input: 10 k $\Omega$   $\pm$  10 %

### Load circuit

Fixed screw terminal: 75°C copper conductors only  
AWG 18 - 8 Sol Torque 0.8 Nm or  
AWG 18 - 10 Str Torque 0.8 Nm  
(only possible at variants up to 30 A)

Temperature range: 0 ... 40 °C

Frequency range: 50 / 60 Hz

Pollution degree: 2

In the final circuit an overvoltage protector R/CSPD (VZCA2/8) with min. 480V AC, 50/60Hz, VPR=2500V, Type 3 has to be installed.



Technical data that is not stated in the UL-Data, can be found in the technical data section.

### Standard Type

BF 9250.91/042  $U_H$  AC/DC 24 V DC 0 ... 10 V AC 230 ... 480 V AC 10 A  
Article number: 0059168  
• 1-pole  
• Control input: DC 0 ... 10 V  
• Auxiliary voltage: AC/DC 24 V  
• Load voltage: AC 230 ... 480 V  
• Load current: AC 10 A  
• Width: 22.5 mm

### Variants

**BF 9250/002:** Output control with fixed period of 64 cycles, pulse-space ratio according to input signal

**BF 9250/042:** Self optimising, to achieve as short as possible control periods, suitable for infrared lamps

## Characteristics

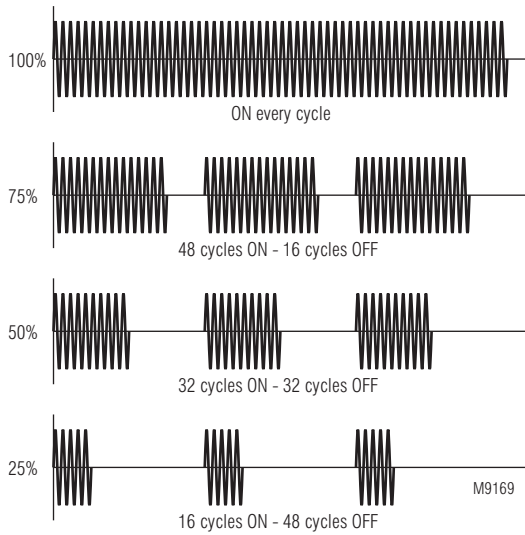
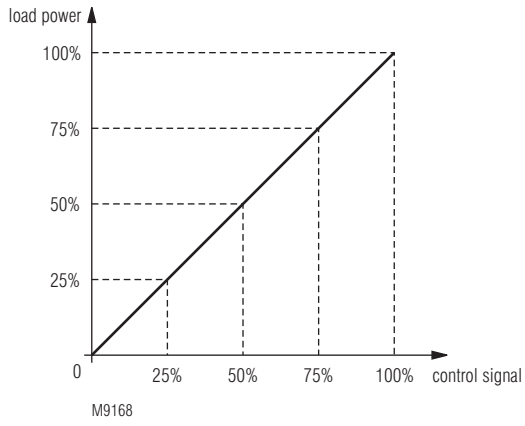

### Variant BF 9250/002

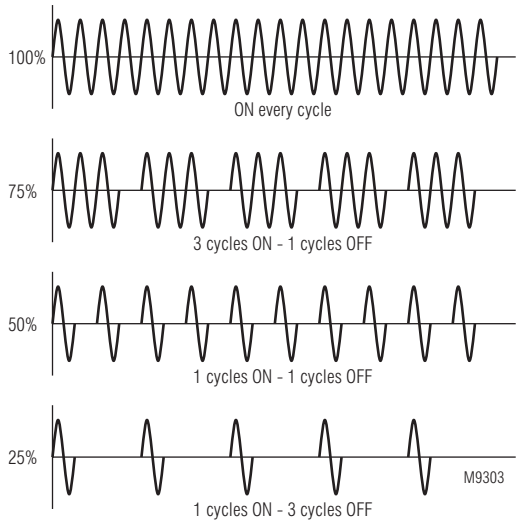

### Variant BF 9250/042

